

LETTER SYMBOLS.		FITTING SYMBOLS.	
ABBREVIATION	DESCRIPTION	ABBREVIATION	DESCRIPTION
AC	AIR CONDITIONING	AC	AIR CONDITIONING
...

AIR CONDITIONING UNIT SCHEDULE						
UNIT NO.	QTY	AREA SERVED	TYPE OF UNIT	RECORDING CAPACITY (RTON)	SUPPLY AIR (CFM)	MAIN PIPE SIZE (INCH)
AC-01	1
AC-02	1

<p>AC-01</p> <p>AC-02</p>

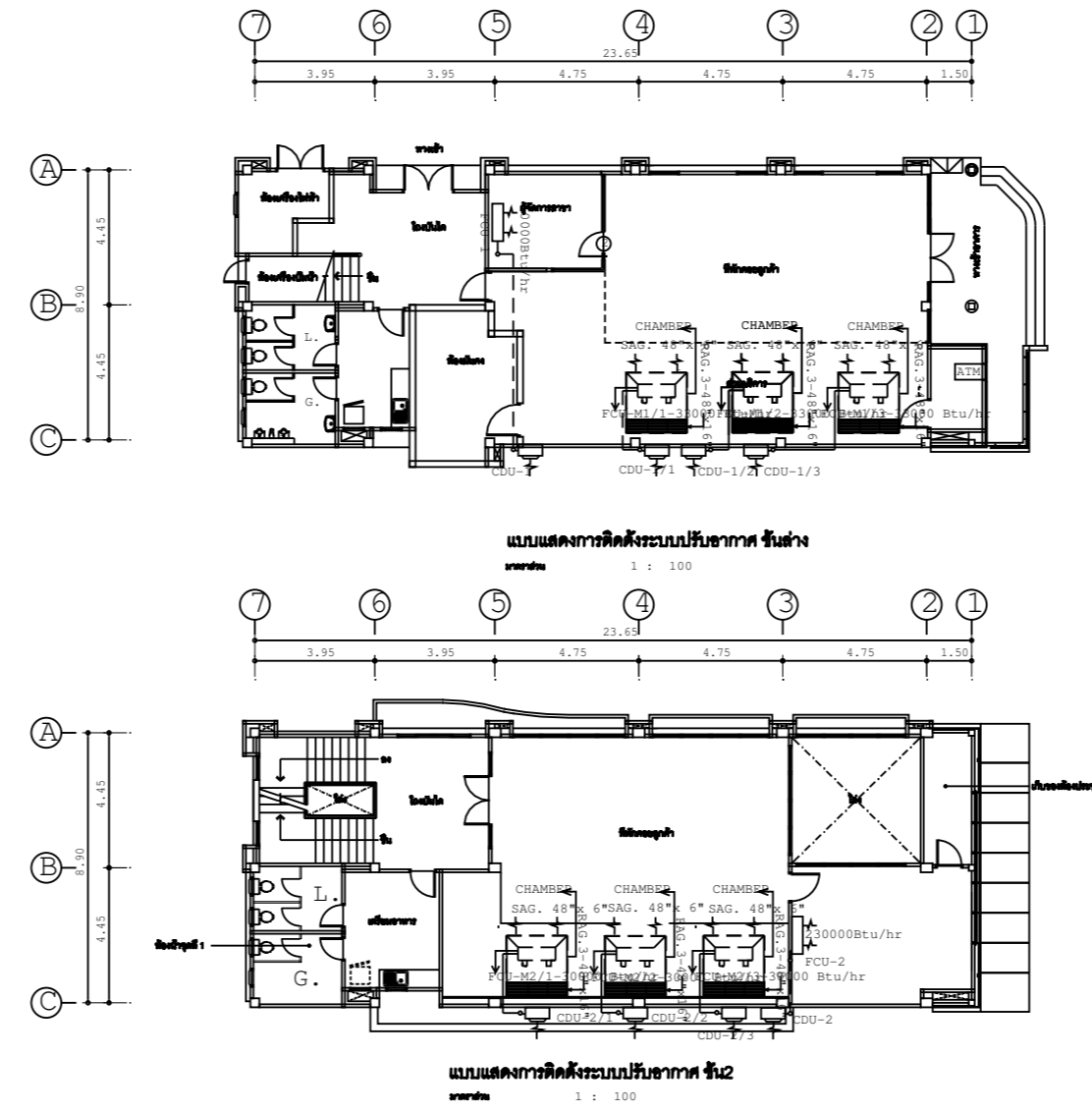

<p>AC-01</p> <p>AC-02</p>

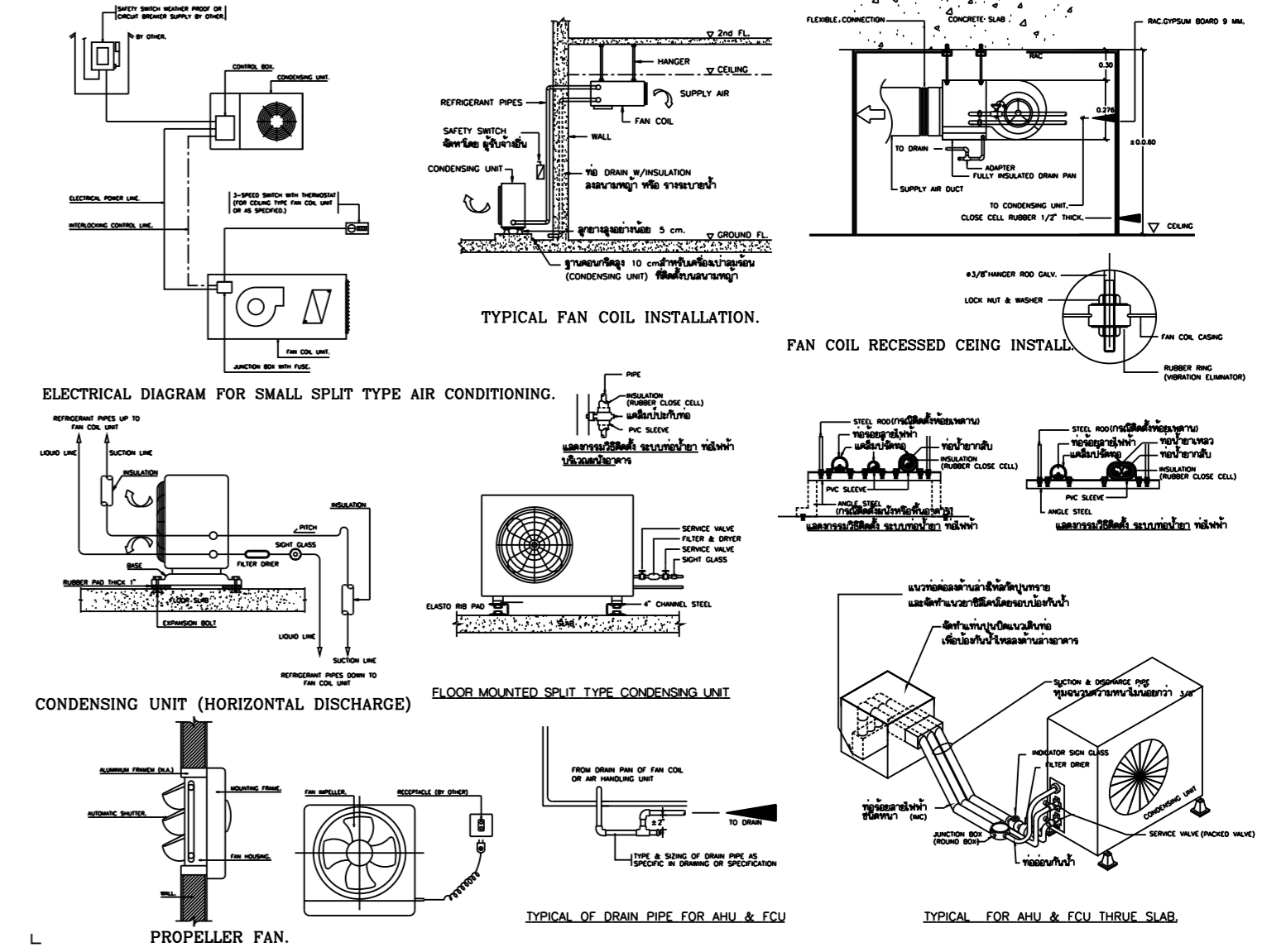

<p>AC-01</p> <p>AC-02</p>

