

FLAT SLAB

FLAT SLAB

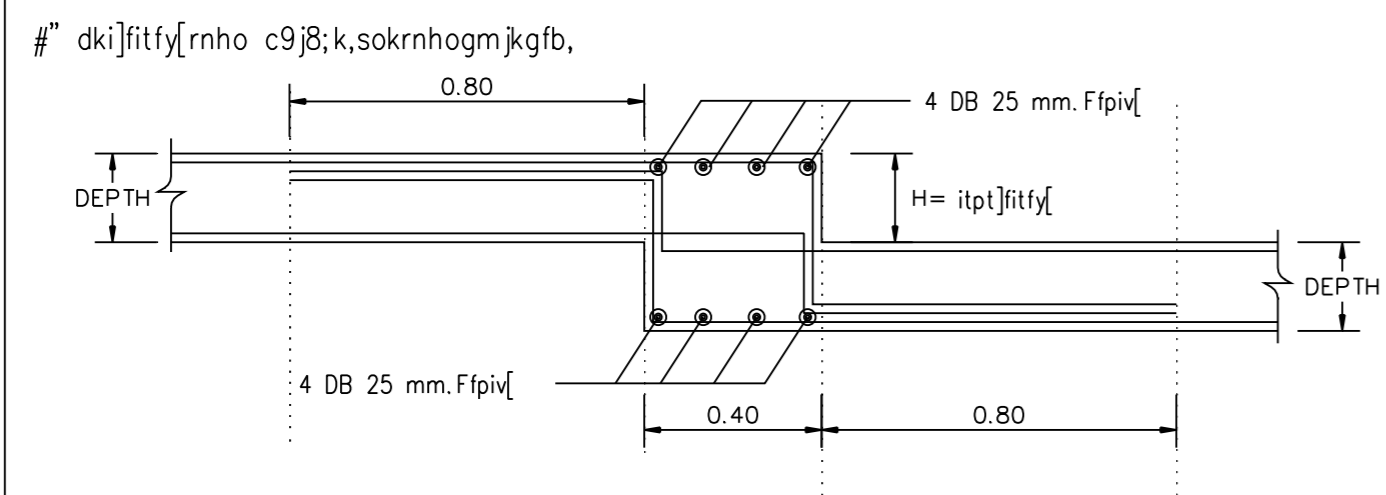

FLAT SLAB

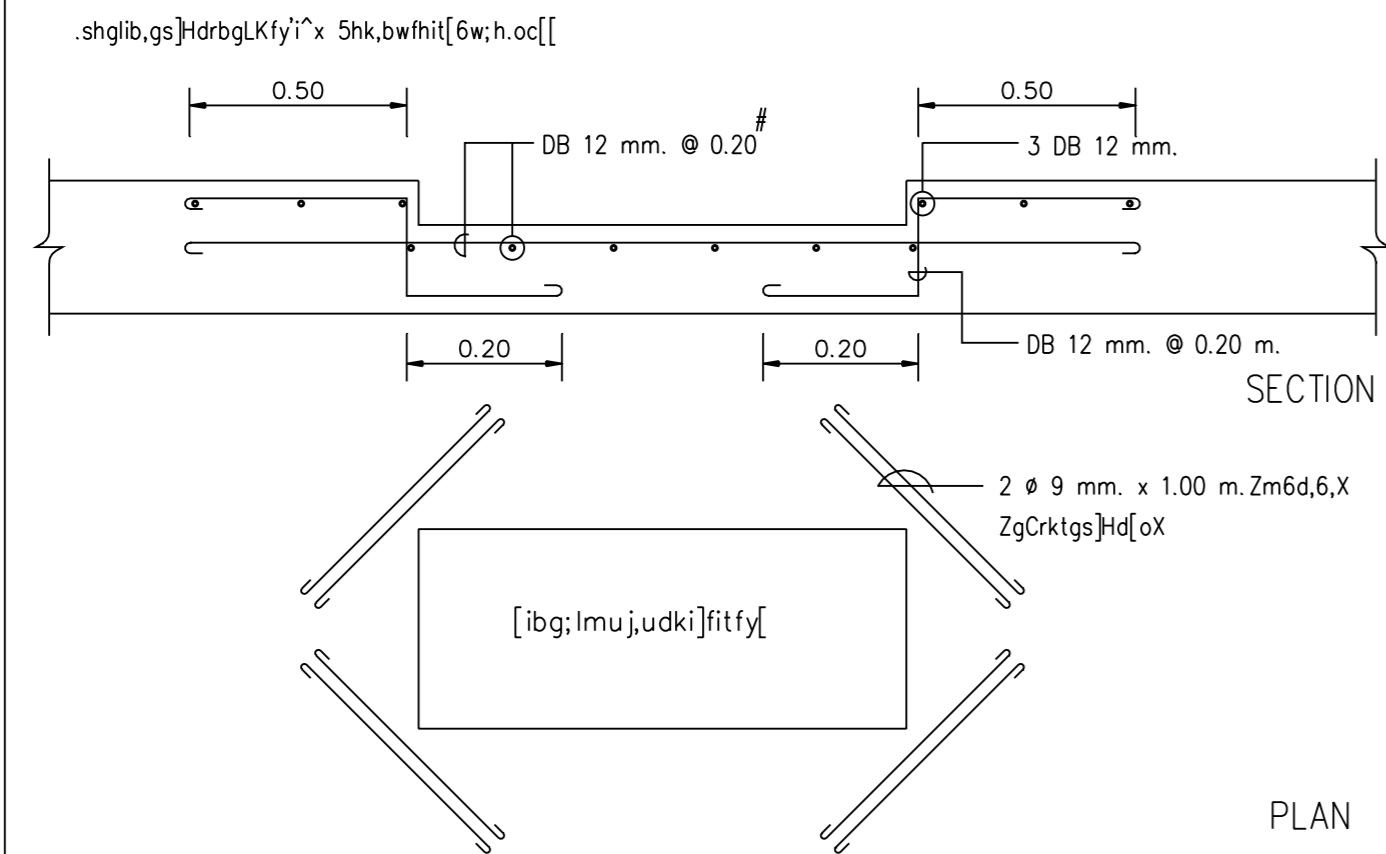
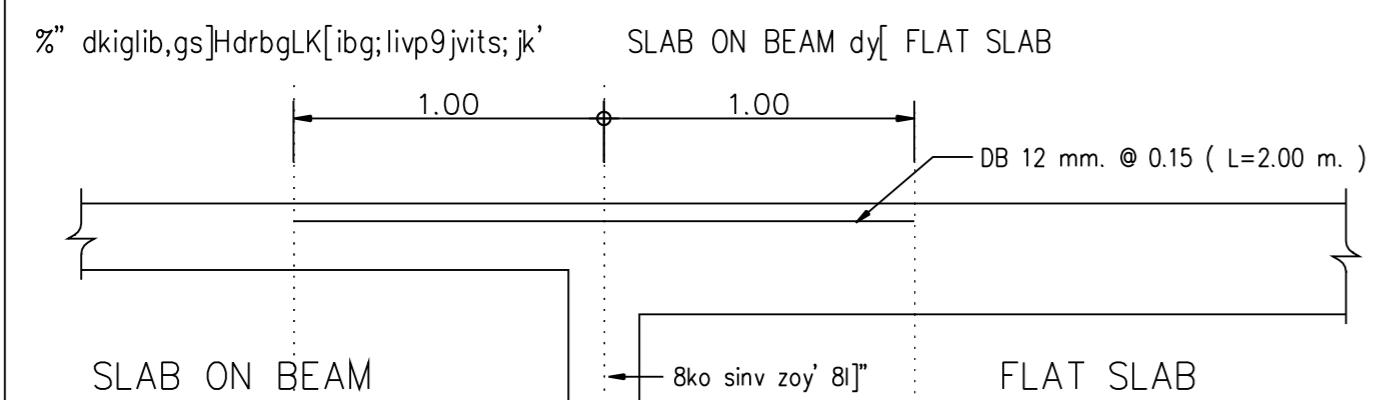
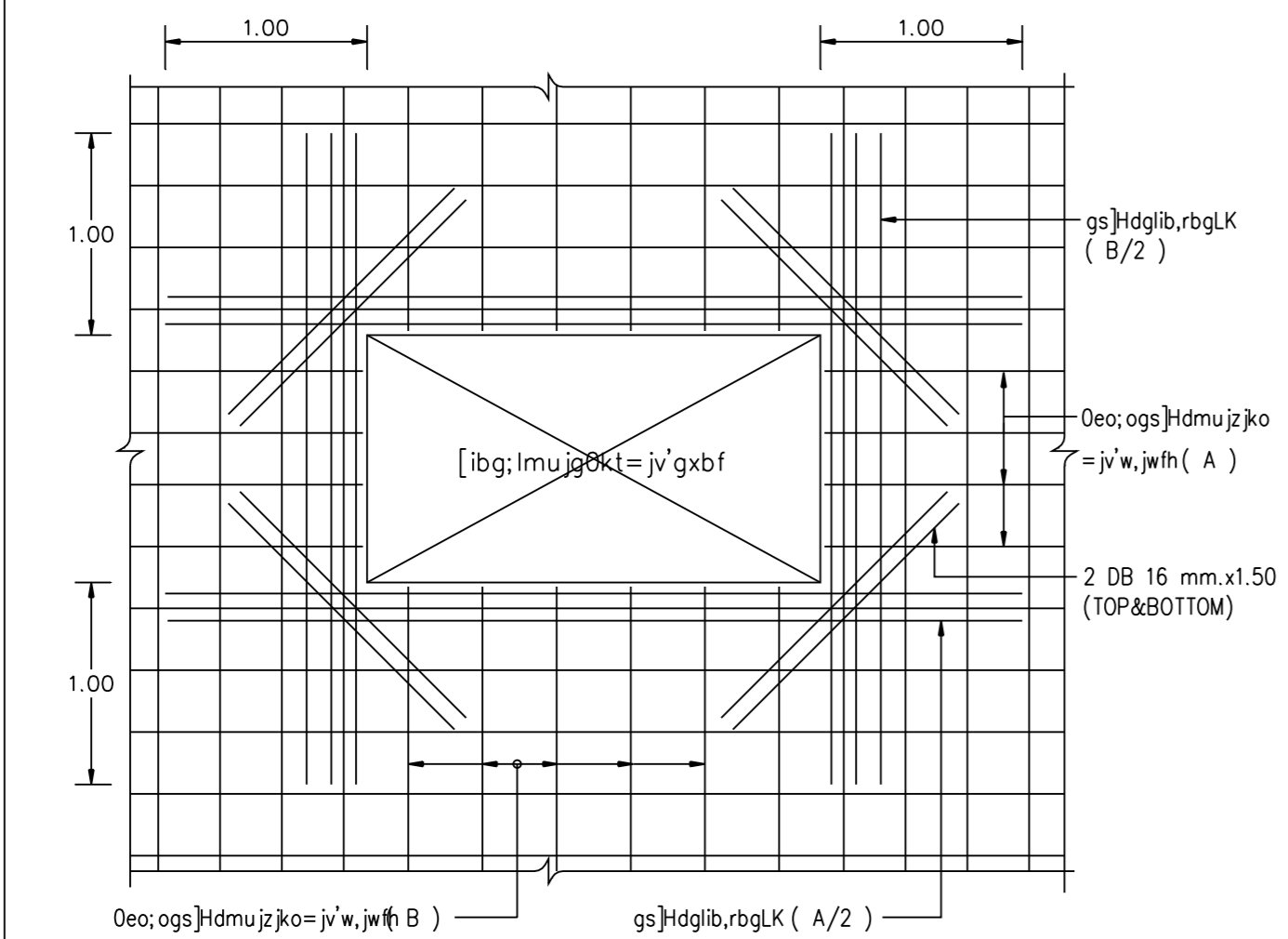

EXPANSION JOINT @ 250 m.

EXPANSION JOINT @ 250 m.

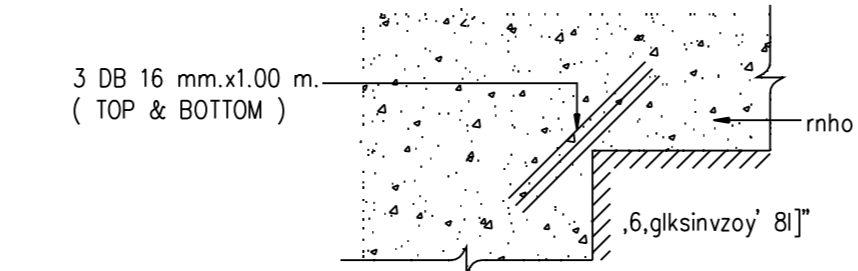

EXPANSION JOINT

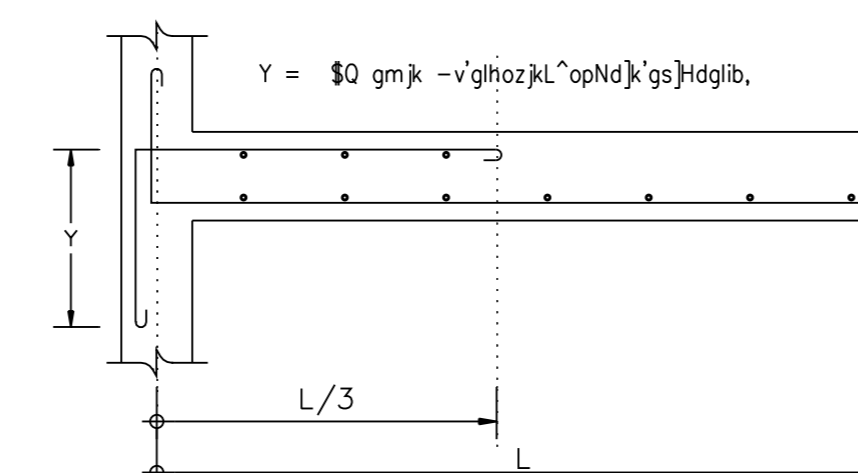

EXPANSION JOINT

EXPANSION JOINT

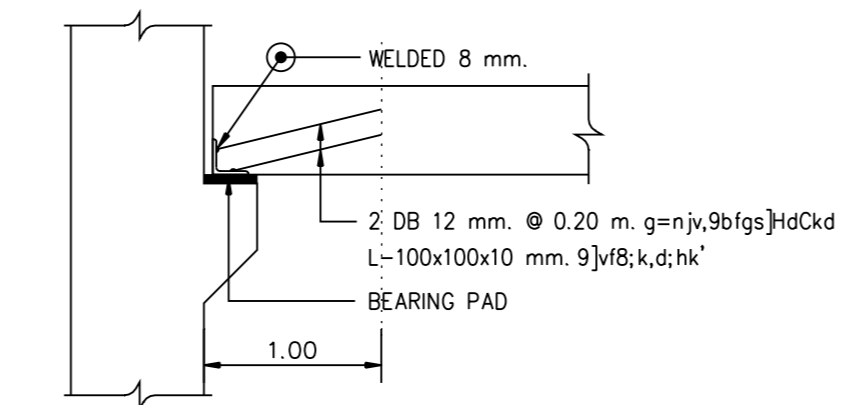

JOINT 'ko5oo

JOINT 'ko5oo

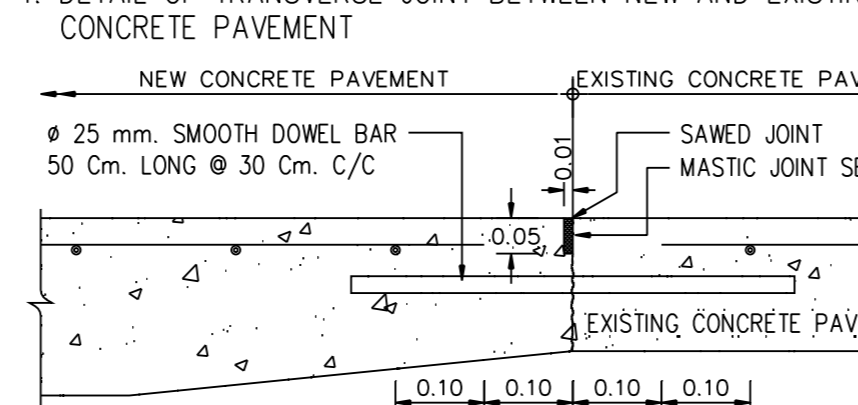

JOINT BETWEEN CONCRETE PAVEMENT AND FLEXIBLE PAVEMENT

JOINT BETWEEN CONCRETE PAVEMENT AND FLEXIBLE PAVEMENT

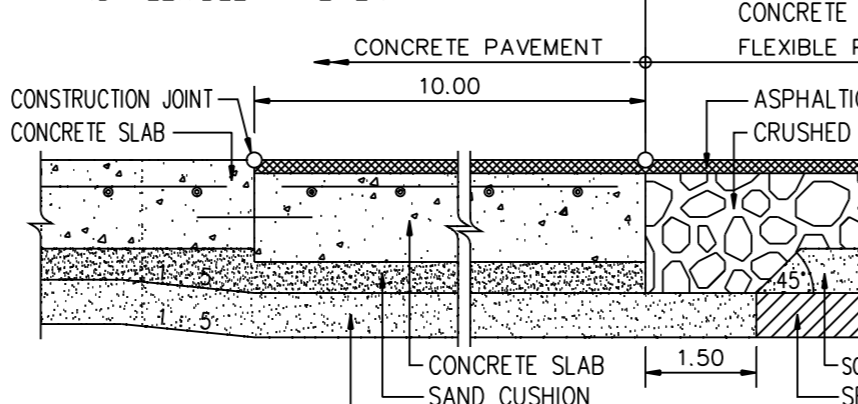

REINFORCEMENT DETAIL OF CONCRETE PAVEMENT (CROSS - SECTION)

REINFORCEMENT DETAIL OF CONCRETE PAVEMENT (CROSS - SECTION)

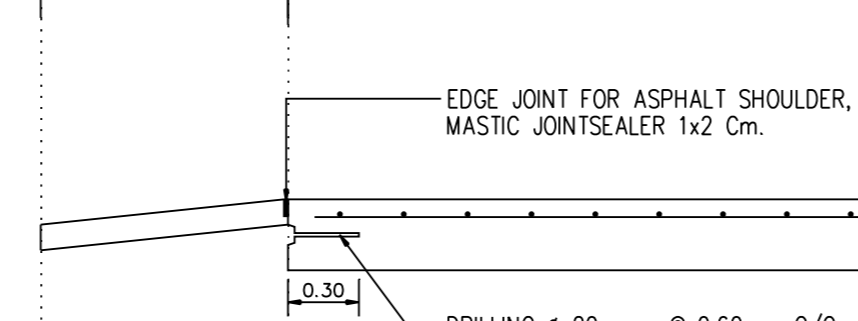

CONSTRUCTION JOINT

CONSTRUCTION JOINT

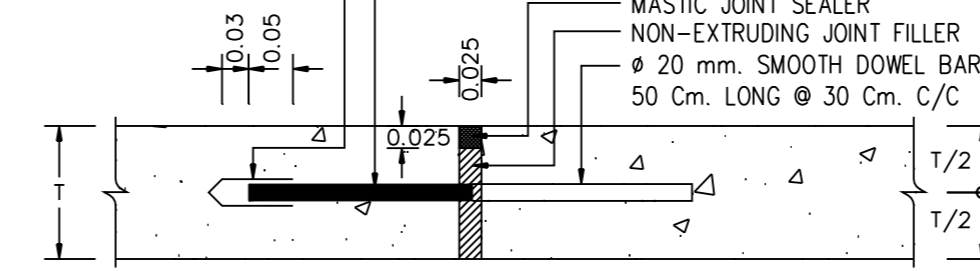

CONSTRUCTION JOINT

CONSTRUCTION JOINT

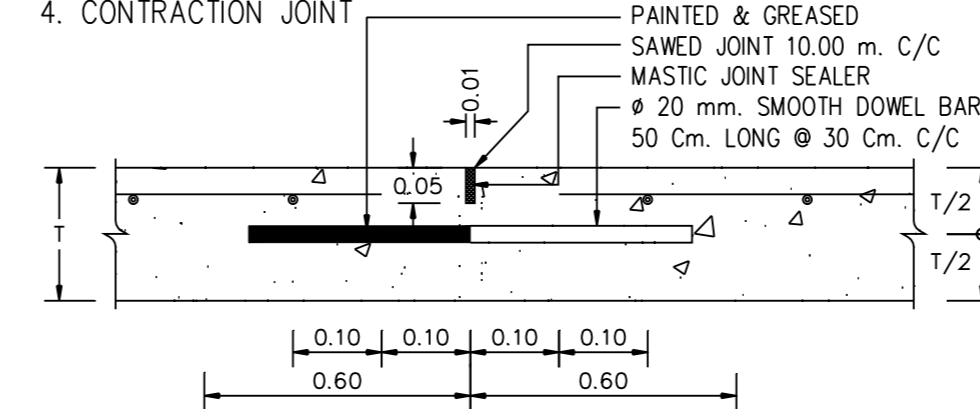

CONSTRUCTION JOINT

CONSTRUCTION JOINT

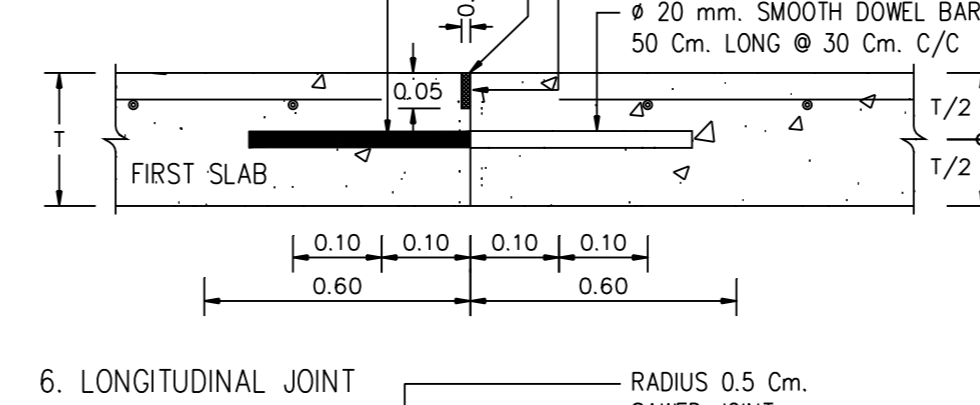

LONGITUDINAL JOINT

LONGITUDINAL JOINT

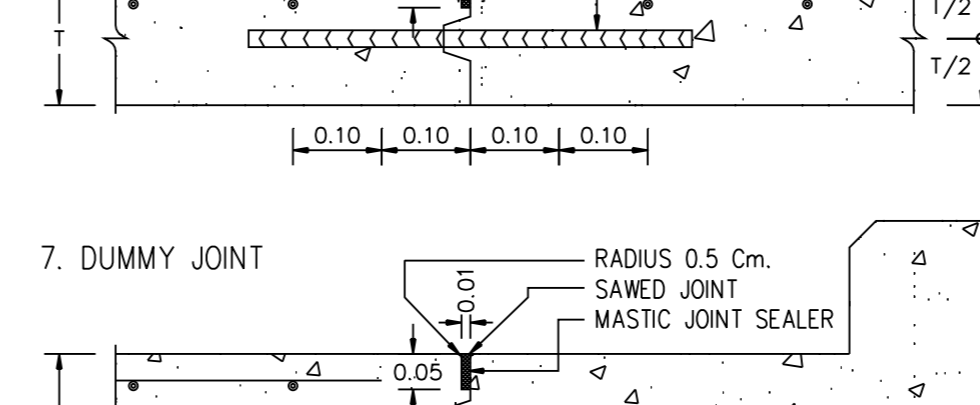

DUMMY JOINT

DUMMY JOINT

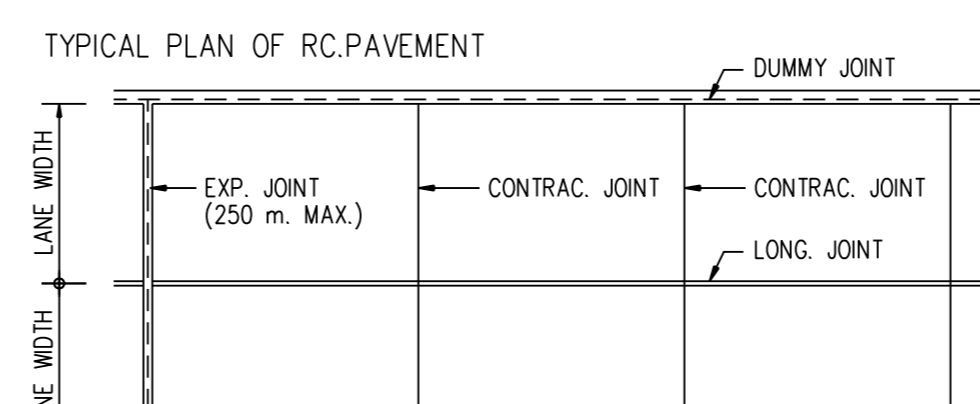

TYPICAL PLAN OF RC.PAVEMENT

TYPICAL PLAN OF RC.PAVEMENT

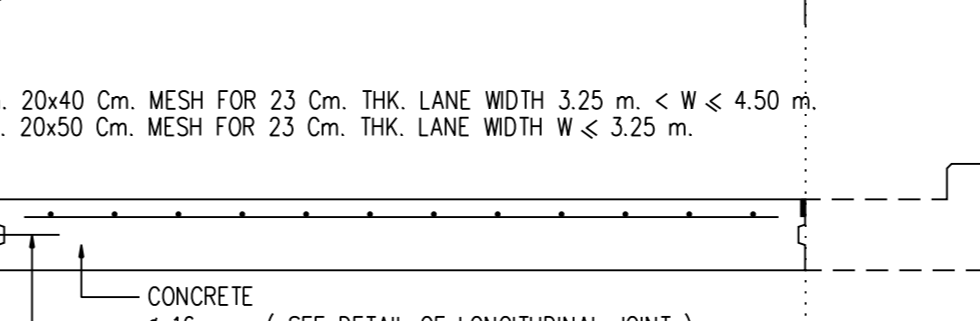

REVISIONS

REVISIONS

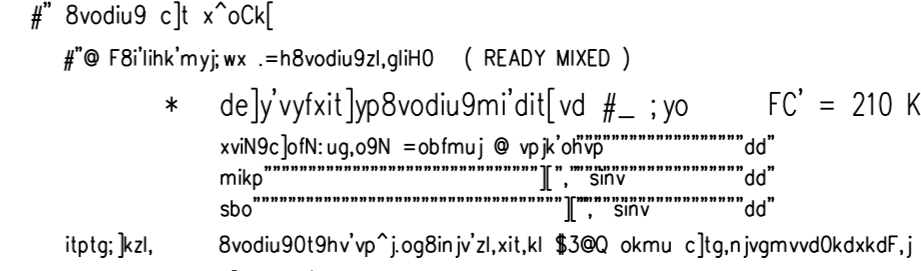

DATE

DATE

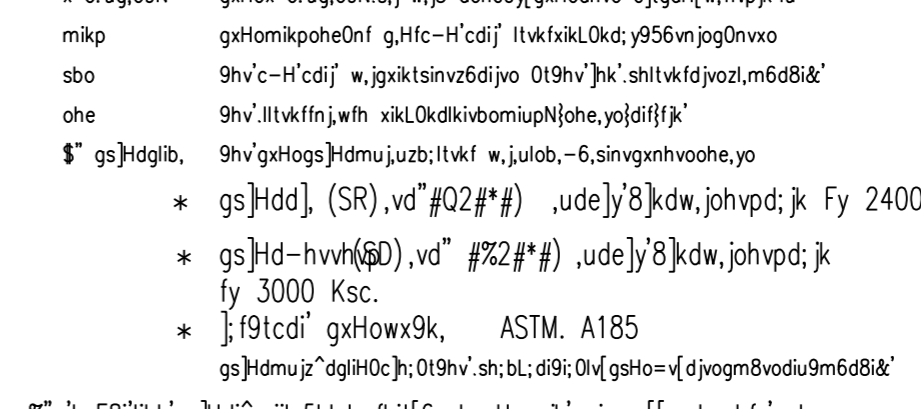

NOTE

NOTE

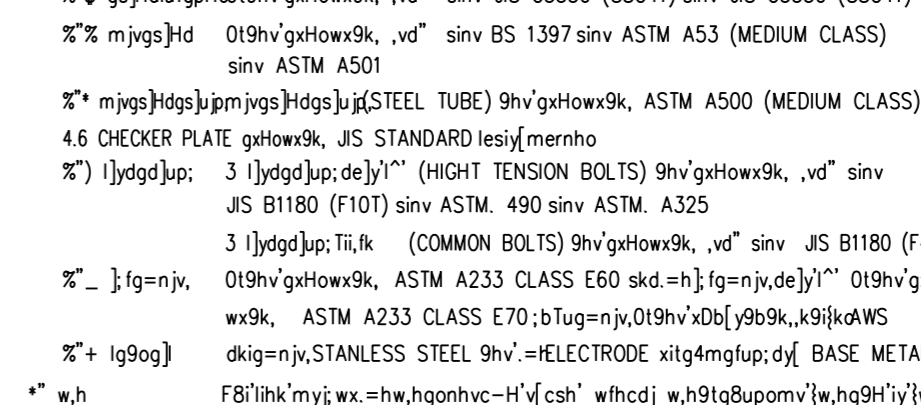

OWNER

OWNER

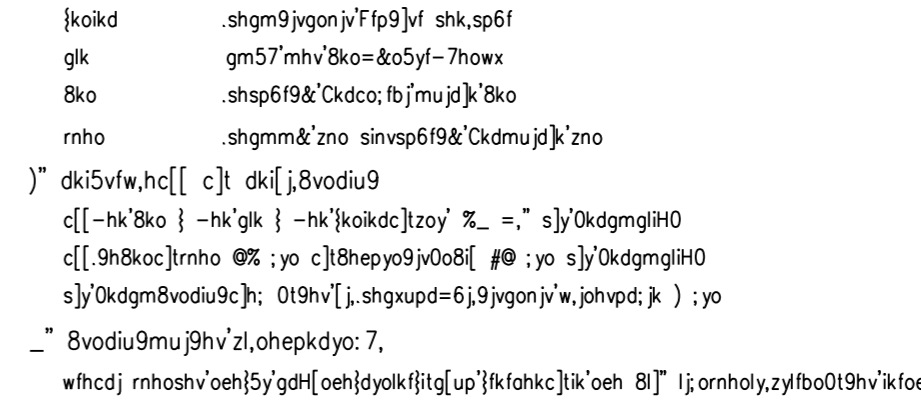

DESIGNER

DESIGNER

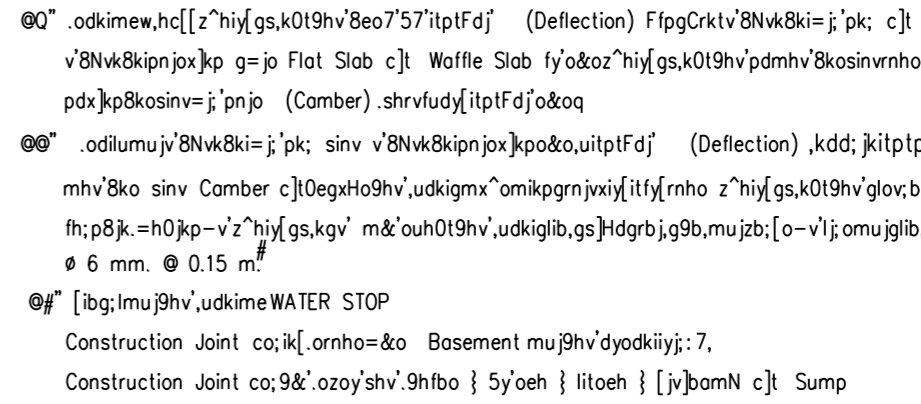

ASSISTANT ARCHITECT

ASSISTANT ARCHITECT



REVISIONS

REVISIONS

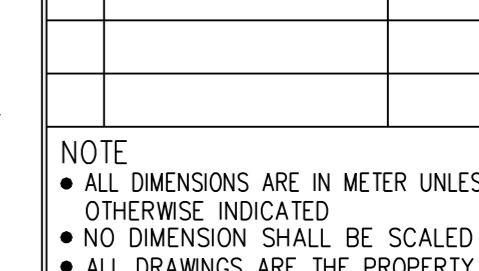

DATE

DATE



NOTE

NOTE

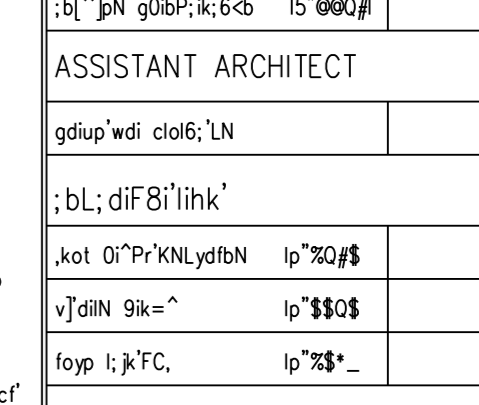

OWNER

OWNER

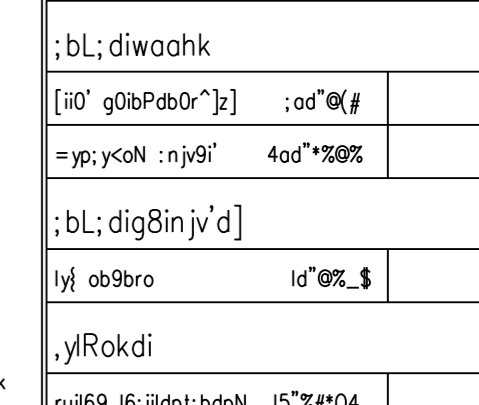

DESIGNER

DESIGNER

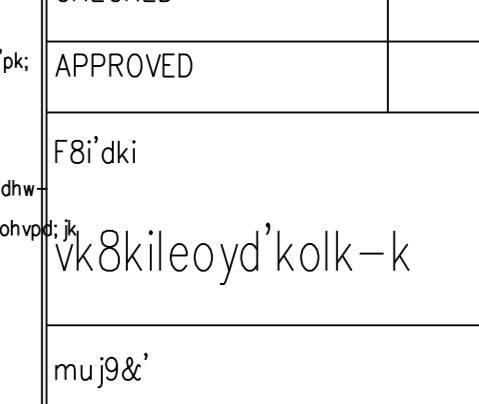

ASSISTANT ARCHITECT

ASSISTANT ARCHITECT

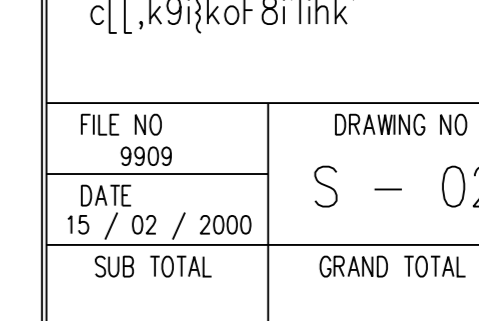

Area-A2(roll) 390x600mm.

